

WH231 / WR231

General Features

The model WH231 or WR231 grinder pump station is a complete unit that includes: the grinder pump, check valve, polyethylene tank, controls, and alarm panel. The lower portion of the tank has a smaller diameter, tapered down to a dish-shaped bottom. These design features reduce the retained volume and promote scouring, which will minimize odor and corrosiveness.

- Rated for flows of 850 gpd (3218 lpd)
- 237 gallons (874 liters) of capacity
- Standard outdoor heights range from 55 inches to 92 inches

The WH231 is the "hardwired," or "wired," model where a cable connects the motor controls to the level controls through watertight penetrations.

The WR231 is the "radio frequency identification" (RFID), or "wireless," model that uses wireless technology to communicate between the level controls and the motor controls.

Operational Information

Motor

1 hp, 1,725 rpm, high torque, capacitor start, thermally protected, 120/240V, 60 Hz, 1 phase

Inlet Connections

4-inch inlet grommet standard for DWV pipe. Other inlet configurations available from the factory.

Discharge Connections

Pump discharge terminates in 1.25-inch NPT female thread. Can easily be adapted to 1.25-inch PVC pipe or any other material required by local codes.

Discharge

15 gpm at 0 psig (0.95 lps at 0 m)
11 gpm at 40 psig (0.69 lps at 28 m)
7.8 gpm at 80 psig (0.49 lps at 56 m)

Accessories

E/One requires that the Uni-Lateral, E/One's own stainless steel check valve, be installed between the grinder pump station and the street main for added protection against backflow.

Alarm panels are available with a variety of options, from basic monitoring to advanced notice of service requirements.

The Remote Sentry is ideal for installations where the alarm panel may be hidden from view.

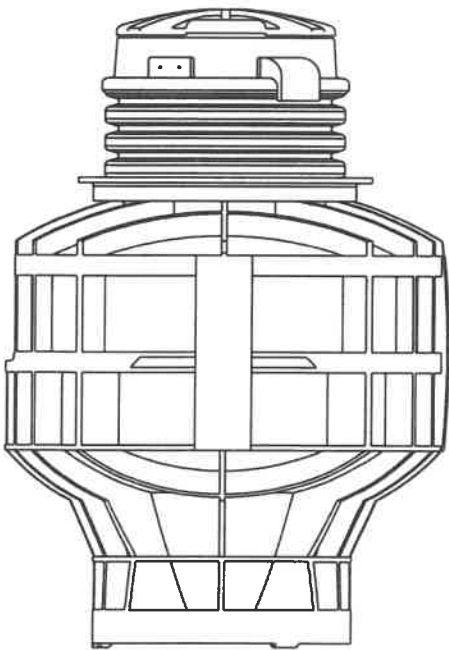

Patent Numbers: 5,752,315
5,562,254 5,439,180

NA0059P01 Rev C

OPTIONS : **WH231** (HARD WIRED LEVEL CONTROLS)
 WR231 (WIRELESS LEVEL CONTROLS)

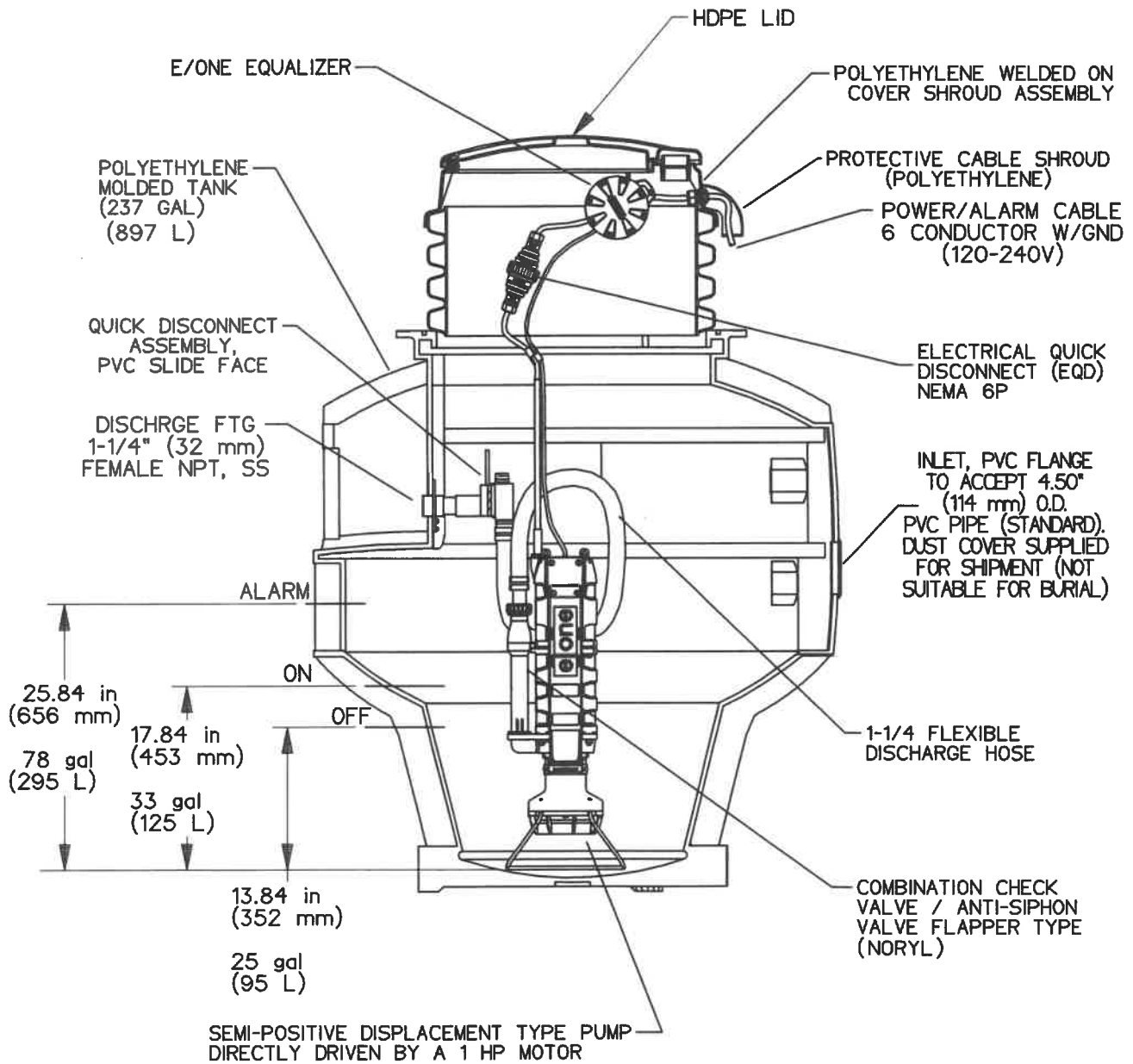

CONCRETE BALLAST MAY BE REQUIRED
 SEE INSTALLATION INSTRUCTIONS
 FOR DETAILS

NOTE: DIMENSIONS ARE FOR REF ONLY

AD	SGS	12/23/10	F	
DR BY	CHK'D	DATE	ISSUE	SCALE
				
MODEL WH231 / WR231 DETAIL SHEET				
NA0059P02				

OPTIONS : **WH231-92** (HARD WIRED LEVEL CONTROLS)
 WR231-92 (WIRELESS LEVEL CONTROLS)

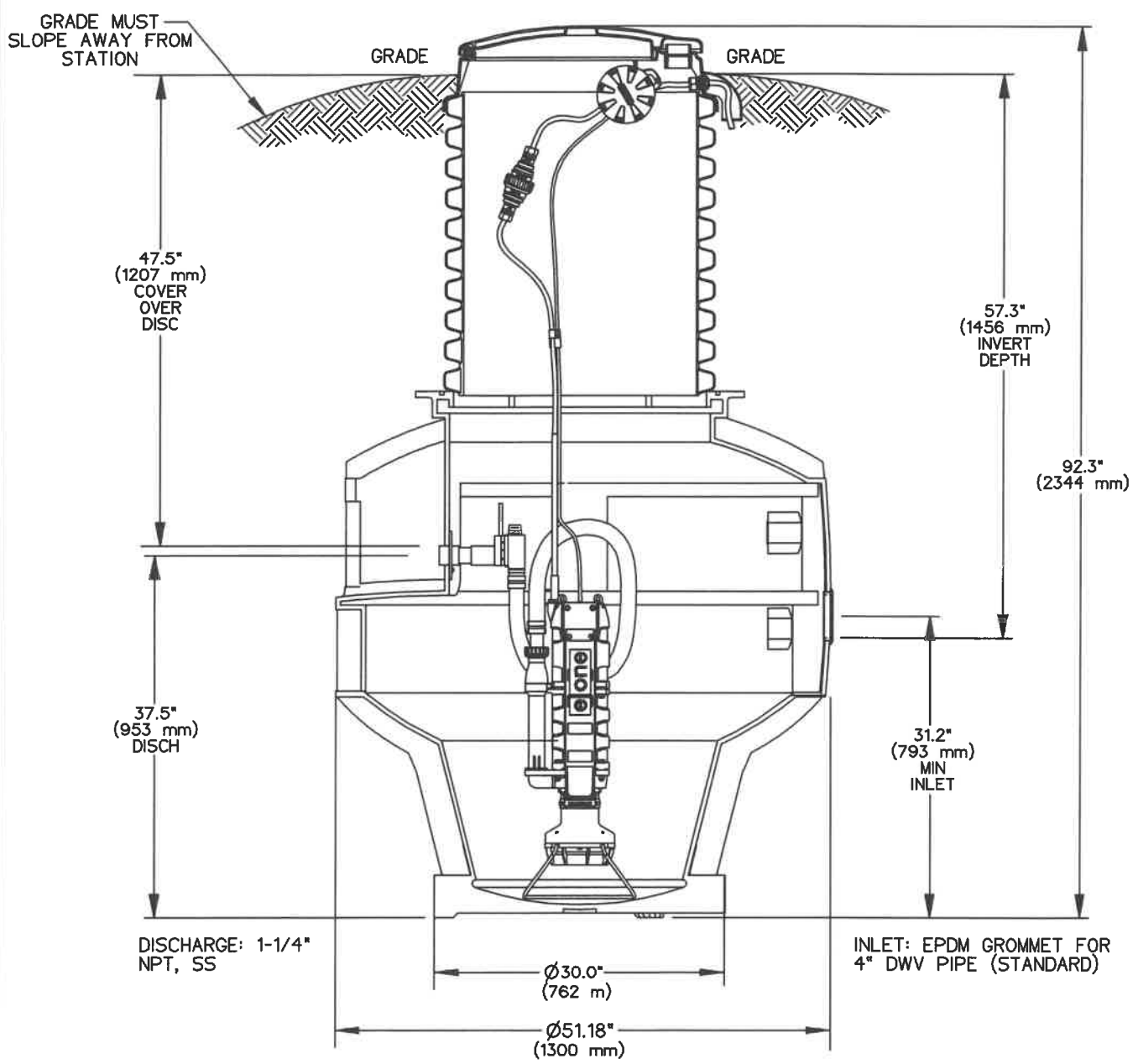

CONCRETE BALLAST MAY BE REQUIRED
 SEE INSTALLATION INSTRUCTIONS
 FOR DETAILS

NOTE: DIMENSIONS ARE FOR REF ONLY

AD	SGS	12/23/10	D	
DR BY	CHK'D	DATE	ISSUE	SCALE
				
MODEL WH231-92 / WR231-92				
NA0059P05				